

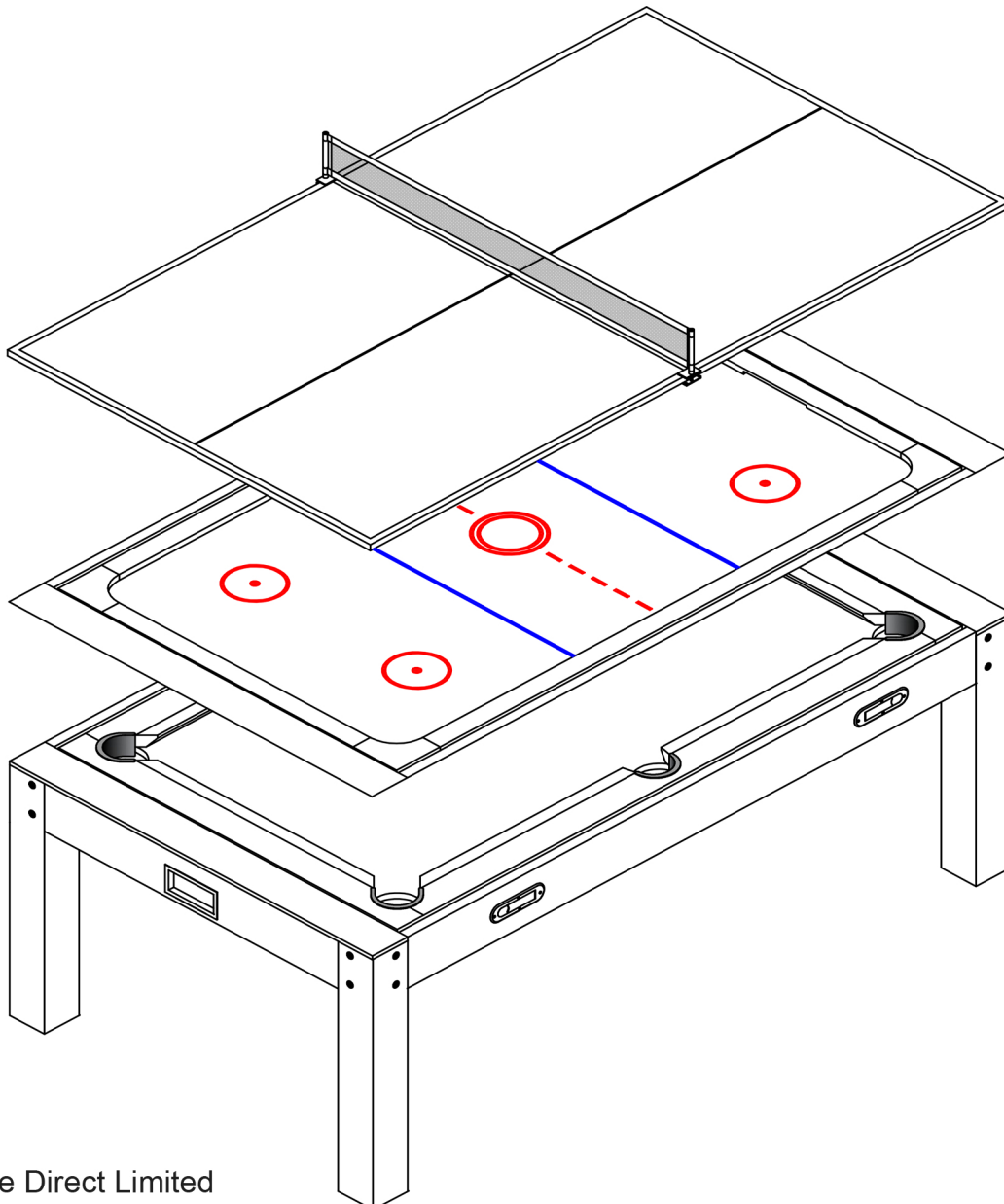

INSTRUCTION MANUAL

Signature Crawford 4 in 1

Pool, Dining, Air Hockey & Table Tennis Table



Home Leisure Direct Limited
Unit 7A/7B Point 4 Distribution Centre,
Second Way, Bristol, BS11 9DF



ASSEMBLY INSTRUCTIONS FOR THE SIGNATURE CRAWFORD 4-in-1 POOL, DINING, AIR HOCKEY & TABLE TENNIS TABLE

Keep these instructions for future reference. Adult assembly required, 4 adults needed for lifting. This table is intended for use by or under the supervision of adults.

Tools Required:

Philips Screwdriver - not included

Standard flat head screwdriver - not included

Allen Key - Included

NOTE: Electric screwdrivers may be used during assembly if set at a low torque. Use with extreme caution.

Assembly Tips:









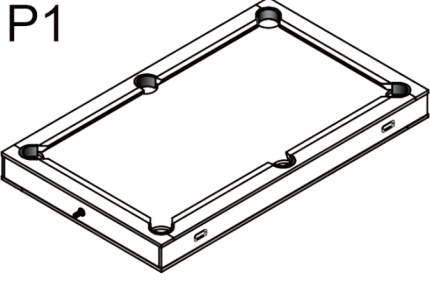
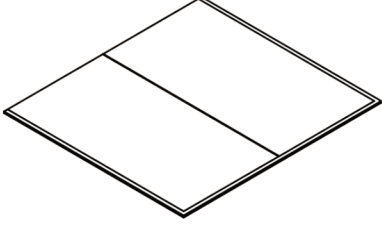
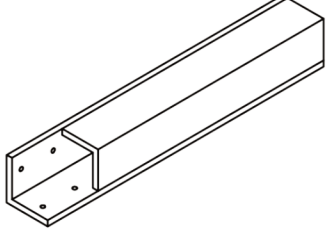
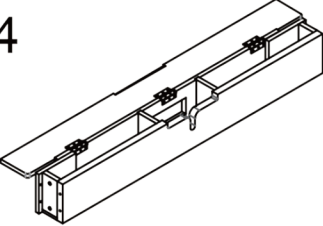
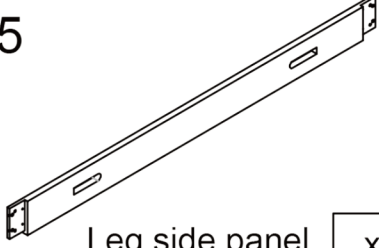

Make sure the following is understood before you begin to assemble this table.

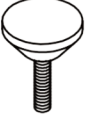
1. READ THIS MANUAL IN FULL before beginning assembly.
2. Some drawings or images in this manual may not look exactly like your product.
3. 2 adults are needed for assembly. 4 adults are needed for lifting.
4. Save all packing materials until the parts have been inspected & the table is assembled.





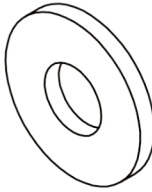
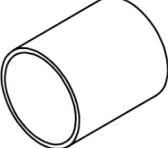
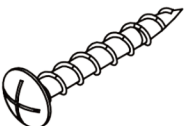

Unpack & Inspect All Pieces

1. Lay the box on a flat surface (ie the floor) ideally in the area of assembly/in the chosen location for the table.
2. Unpack the box and inspect & count the parts. Use the parts identifier pages to ensure all parts are present before beginning assembly.

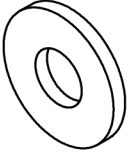
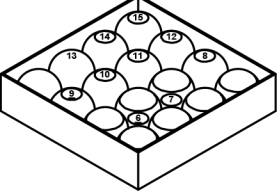
PARTS IDENTIFIER

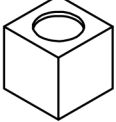
<p>P1</p>  <p>Pool table</p> <p>x1</p>	<p>P2</p>  <p>Table tennis surface</p> <p>x2</p>	<p>P3</p>  <p>Leg</p> <p>x4</p>
<p>P4</p>  <p>Leg End panel</p> <p>x2</p>	<p>P5</p>  <p>Leg side panel</p> <p>x2</p>	<p>P6</p>  <p>Latches</p> <p>x4</p>
<p>P7</p>  <p>Leg leveler</p> <p>x4</p>	<p>P8</p>  <p>Support brace</p> <p>x1</p>	
<p>H1</p>  <p>Bolt</p> <p>x16</p>	<p>H2</p>  <p>Plastic cover</p> <p>x16</p>	<p>H3</p>  <p>Screw</p> <p>x16</p>
<p>H4</p>  <p>Plastic barrel nut</p> <p>x8</p>	<p>H5</p>  <p>Nut</p> <p>x4</p>	<p>H6</p>  <p>Washer</p> <p>x4</p>
<p>H7</p>  <p>Axle sleeve</p> <p>x2</p>	<p>H8</p>  <p>Screw</p> <p>x16</p>	<p>H9</p>  <p>Wood plug</p> <p>x2</p>

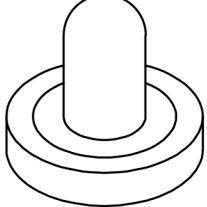
PARTS IDENTIFIER

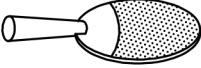
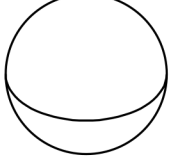
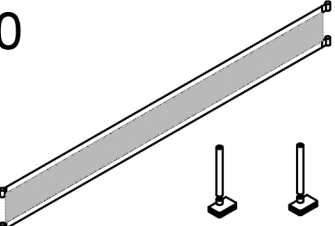
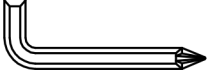
<p>H10</p>  <p>Washer</p> <p>x16</p>		
<p>A1</p>  <p>Billiard ball</p> <p>x1</p>	<p>A2</p>  <p>Triangle rack</p> <p>x1</p>	<p>A3</p>  <p>Chalk</p> <p>x2</p>
<p>A4</p>  <p>Cue stick</p> <p>x2</p>	<p>A5</p>  <p>Plastic brush</p> <p>x1</p>	<p>A6</p>  <p>Hockey striker</p> <p>x2</p>
<p>A7</p>  <p>Hockey Puck</p> <p>x2</p>	<p>A8</p>  <p>Table tennis paddle</p> <p>x2</p>	<p>A9</p>  <p>Table tennis ball</p> <p>x3</p>
<p>A10</p>  <p>Table tennis net</p> <p>x1</p>	<p>A11</p>  <p>Allen key tool</p> <p>x1</p>	

ASSEMBLY INSTRUCTIONS

WARNING: TWO ADULTS NEEDED FOR ASSEMBLY.
FOUR ADULTS NEEDED FOR LIFTING.

Parts Needed: P4 x2, P5 x2, H4 x8, H3 x16

Figures 1 & 2: Assemble the frame (P4 & P5) using parts H4 & H3

Figure 1

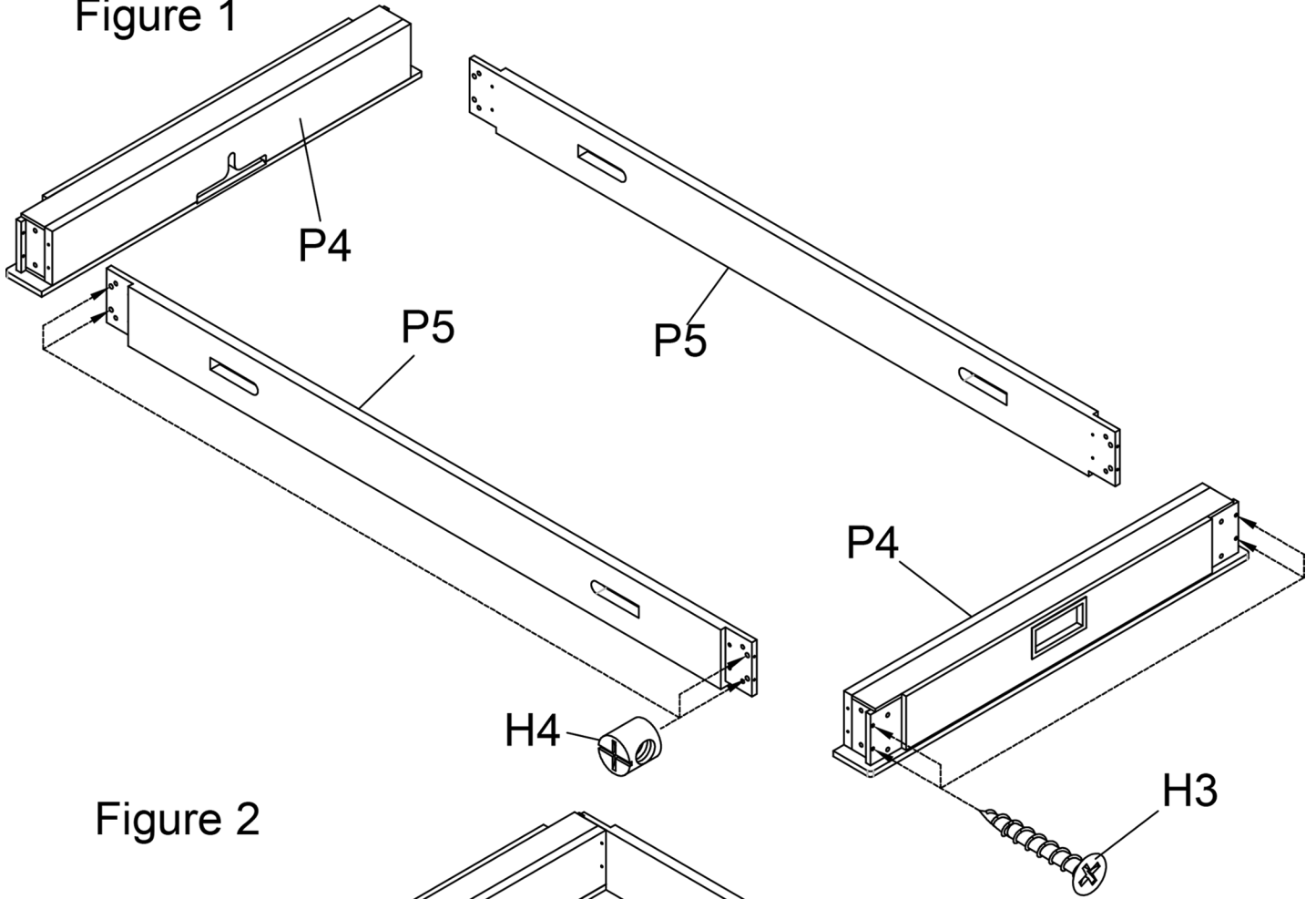
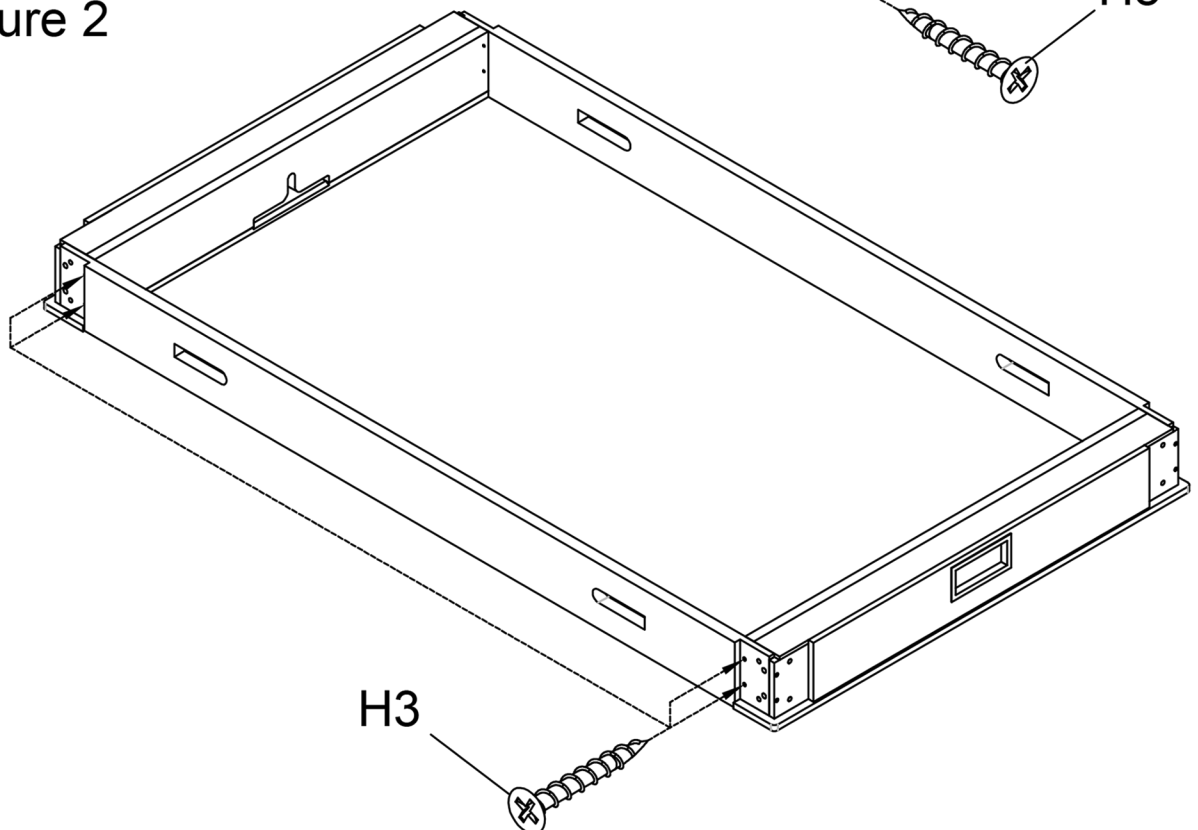

Figure 2



ASSEMBLY INSTRUCTIONS

WARNING: TWO ADULTS NEEDED FOR ASSEMBLY.
FOUR ADULTS NEEDED FOR LIFTING.

Parts Needed: P3 x4, P7 x4, H10 x16, H1 x16, H2 x16

Figure 3: Attach the legs (P3) to the frame using parts H10, H1 & H2.
Attach the leg levellers (P7) to the legs (P3).

Figure 3

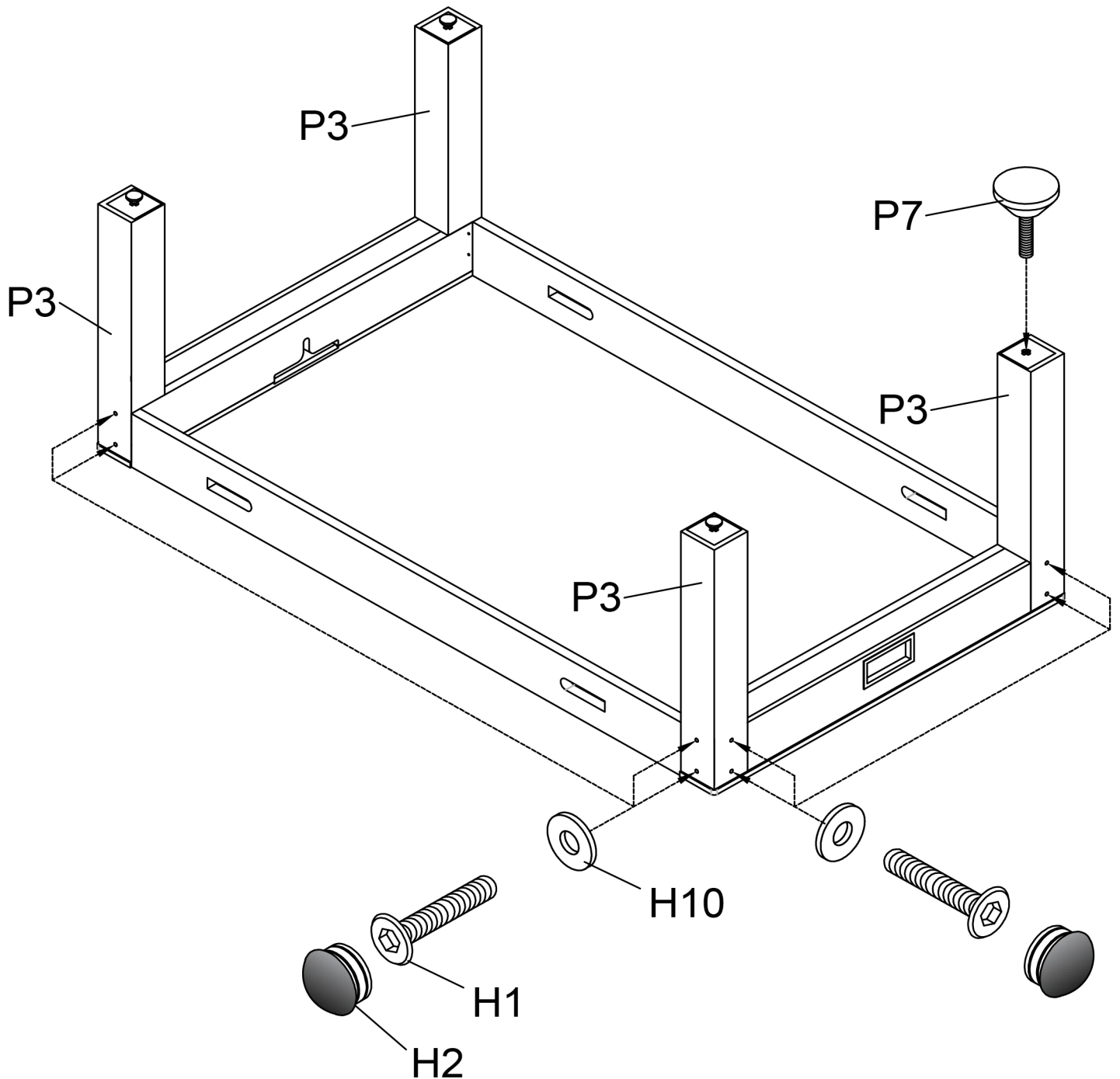

ASSEMBLY INSTRUCTIONS

WARNING: TWO ADULTS NEEDED FOR ASSEMBLY.
FOUR ADULTS NEEDED FOR LIFTING.

Parts Needed: P1 x1, H5 x4, H7 x2, H6 x4

Figure 4: Turn the table upright. Lower the pool table (P1) onto the frame.
Secure the pool table using parts H5, H7 & H6.

Figure 4

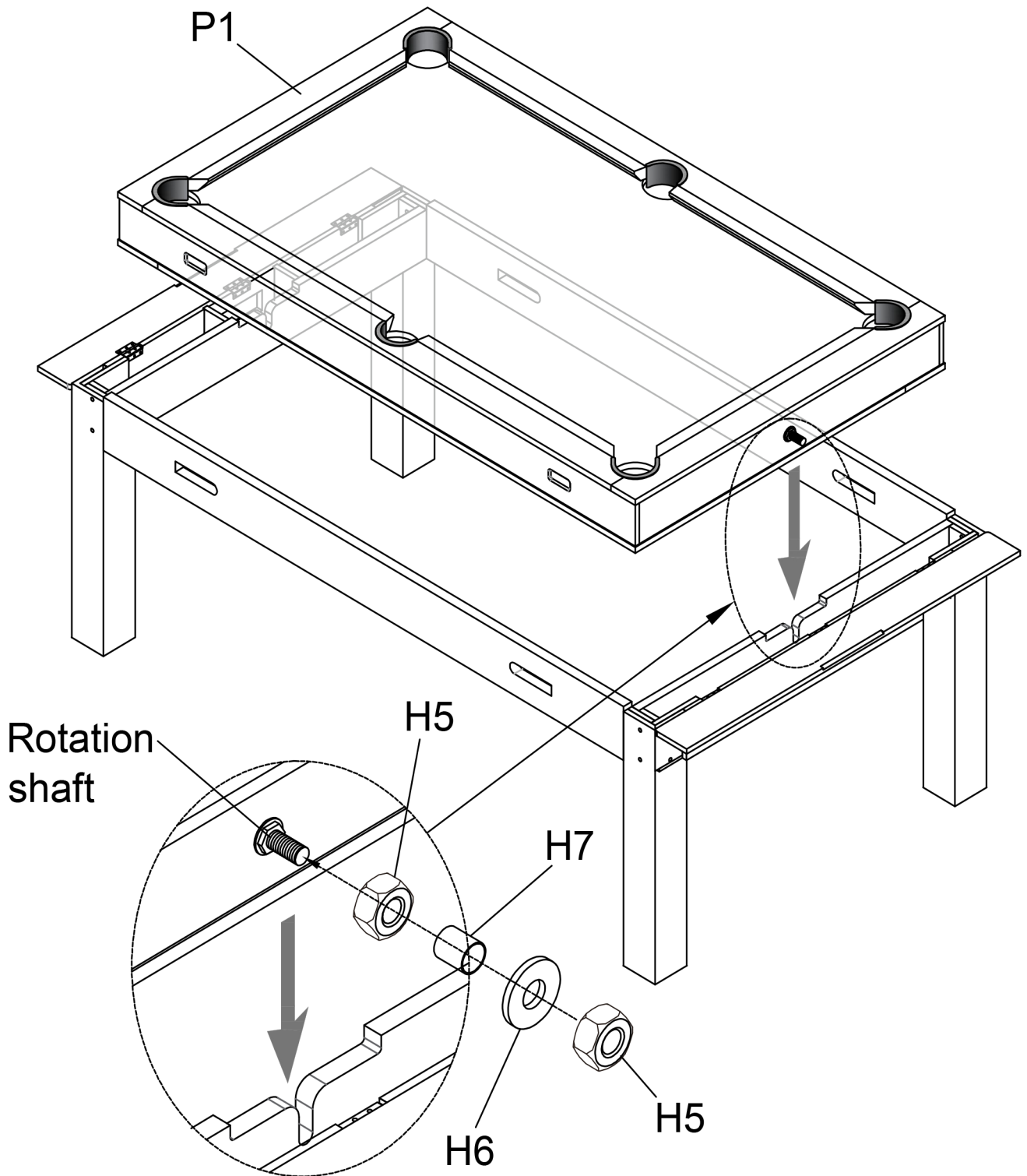

6.

ASSEMBLY INSTRUCTIONS

WARNING: TWO ADULTS NEEDED FOR ASSEMBLY.
FOUR ADULTS NEEDED FOR LIFTING.

Parts Needed: P6 x4, H8 x16

Figure 5: Attach the latches (P6) to the side of the frame. Secure the latches using parts H8.

Figure 5

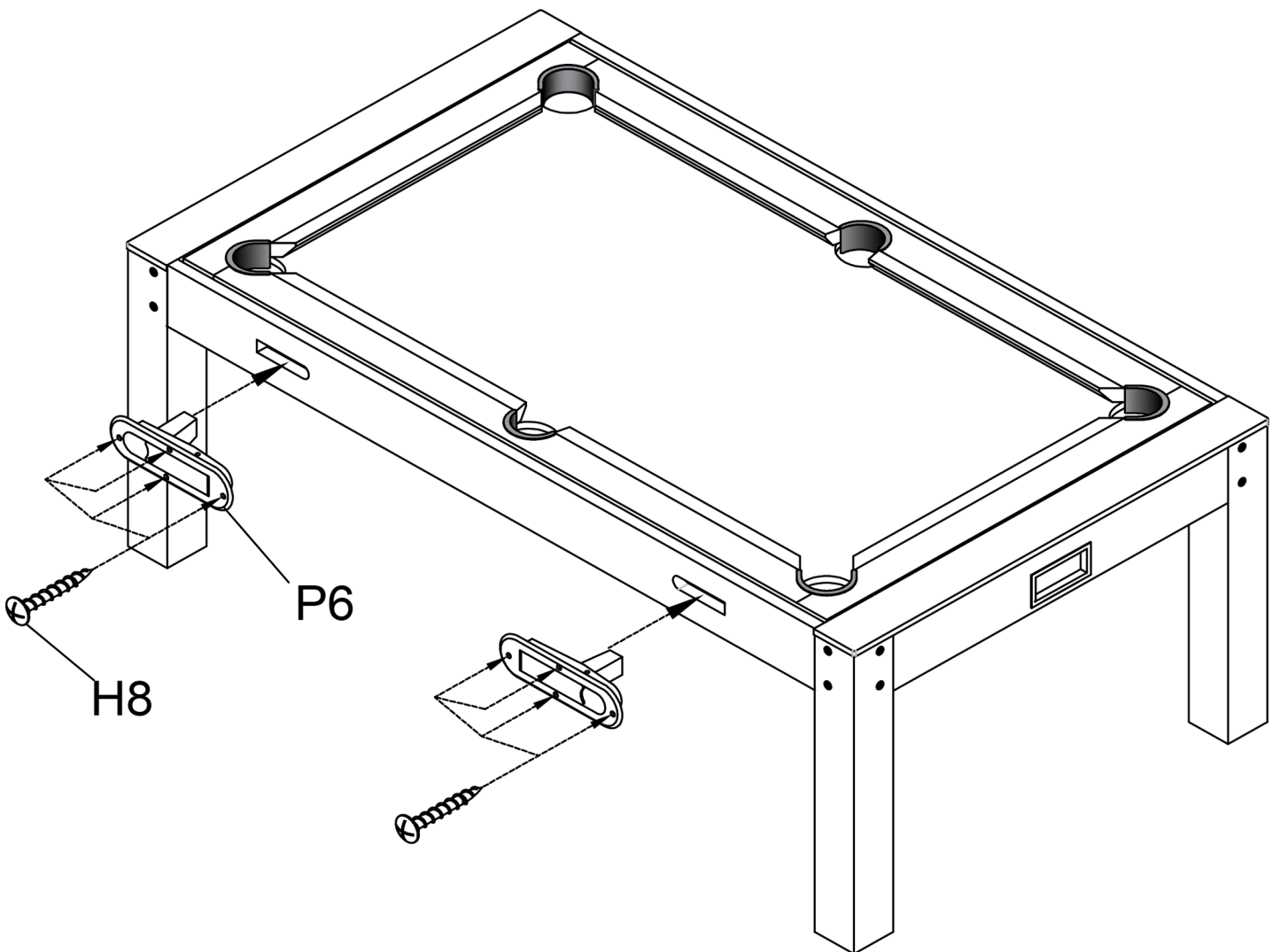

ASSEMBLY INSTRUCTIONS

WARNING: TWO ADULTS NEEDED FOR ASSEMBLY.
FOUR ADULTS NEEDED FOR LIFTING.

Parts Needed: P2 x2, P8 x1, H9 x2, A10 x1

Figure 6: Connect the table tennis surfaces (P2) and support brace (P8) using the wooden plugs (H9). Attach the net (A10).

Figure 6

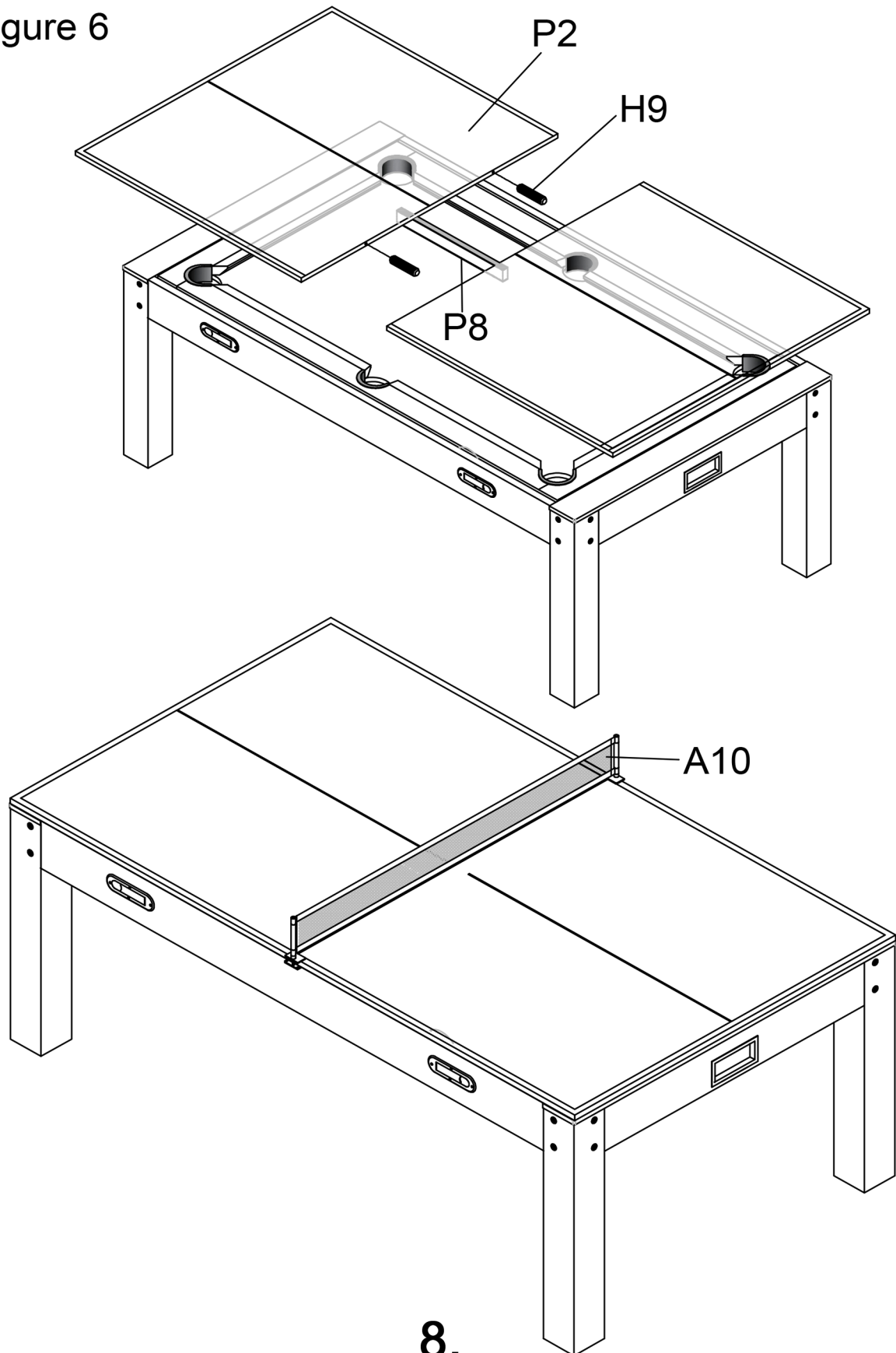

ASSEMBLY INSTRUCTIONS

WARNING: TWO ADULTS NEEDED FOR ASSEMBLY.
FOUR ADULTS NEEDED FOR LIFTING.

Figure 7: Open the latches to revolve the pool table/air hockey table.
Secure the pool table/air hockey table in place by closing the latches.

Figure 7

